

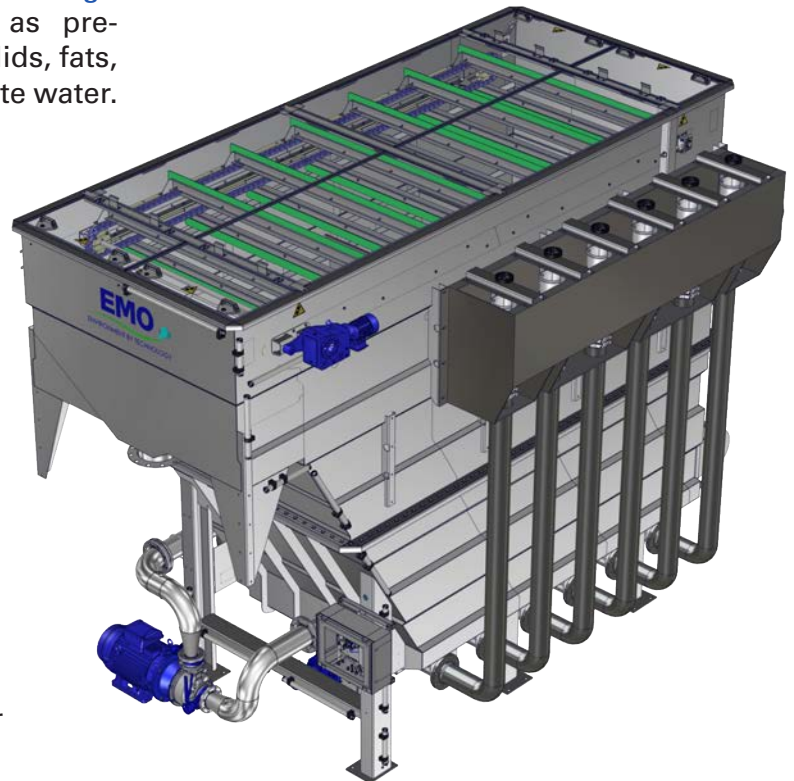

Flotation units with dissolved air allow to accelerate the separation of water and suspended solids. Compact and simple of use, they make it possible to recover at the same time floated and settling particles, and produce rejections with strong content of dry matter.

The GAMMA flotation units are designed to treat high polluted wastewater; they are very suitable as pre-treatment step for removing of the suspended solids, fats, oil, grease and other floating materials in the waste water.



### ADVANTAGES

- Low cost maintenance
- Recovery of solids on the surface and at the bottom of the flotation unit
- Possible use of additives (coagulation and/or flocculation)
- Pre-treatment of high polluted wastewater (grease, COD, SS, ...)
- Compact equipment with a lamellar pack for high treatment capacity (optimum space requirement/efficiency ratio)
- Flowrate from 225 to 650 m<sup>3</sup>/h





## OPERATING PRINCIPLE

What makes this dissolved air flotation unit special is the **use of micro-bubbles** of air to separate suspended solids or grease from the water. The microbubbles are created by dissolving air in water under pressure. When this air-saturated water is mixed with raw water, very fine bubbles are formed, giving the water a milky appearance; this is the reason it is most commonly called «white» water.

The air bubbles formed attach themselves to the solid particles and cause them to float. At the surface, the floating particles are scraped off and carried to a discharge hopper.

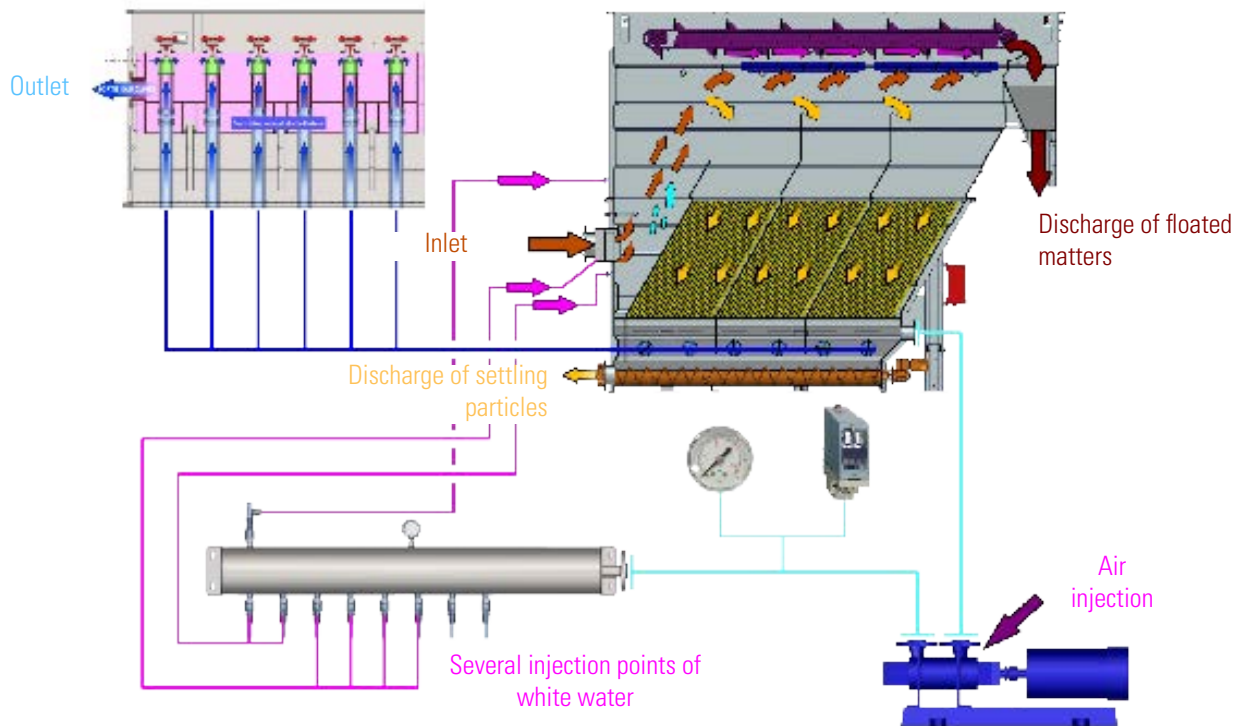

## RANGE & APPLICATIONS

A range of 6 flotation units adapted to any type of effluent for a unit flow rate of 225 to 650 m<sup>3</sup>/h: the food industry (dairy, slaughterhouses, fish industry, processing plants, etc.), the petrochemical industry, paper industry, textile industry, urban wastewater treatment plants and drinking water, sludge thickening (wastewater, drinking water), etc...



**EMO sas**

4 rue Lépine – PA La Richardière, BP 53209, 35530 Noyal sur Vilaine, France  
+ 33 (0)2 99 86 02 03 - [emo@emo-france.com](mailto:emo@emo-france.com)

[www.emo-france.com](http://www.emo-france.com)

Certification ISO9001 - ISO14001



A company of **SEMOSIA**  
GROUP